



# 54LVQ/74LVQ02

## Low Voltage Quad 2-Input NOR Gate

### General Description

The LVQ02 contains four, 2-input NOR gates.

### Features

- Ideal for low power/low noise 3.3V applications
- Guaranteed simultaneous switching noise level and dynamic threshold performance
- Guaranteed pin-to-pin skew AC performance
- Guaranteed incident wave switching into 75Ω

**Ordering Code:** See Section 8

### Logic Symbol

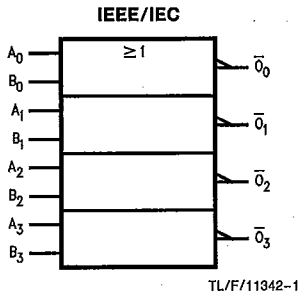

### Connection Diagrams

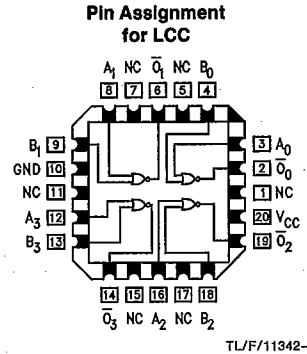
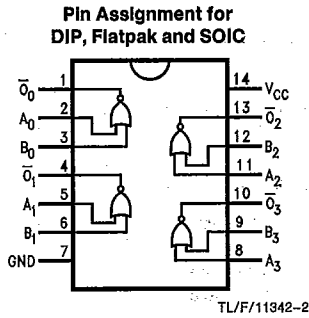

Pin Names	Description
$A_n, B_n$	Inputs
$O_n$	Outputs

### Absolute Maximum Ratings (Note 1)

If Military/Aerospace specified devices are required, please contact the National Semiconductor Sales Office/Distributors for availability and specifications.

Supply Voltage ( $V_{CC}$ )	-0.5V to +7.0V
DC Input Diode Current ( $I_{IK}$ )	
$V_I = -0.5V$	-20 mA
$V_I = V_{CC} + 0.5V$	+20 mA
DC Input Voltage ( $V_I$ )	-0.5V to $V_{CC} + 0.5V$
DC Output Diode Current ( $I_{OK}$ )	
$V_O = -0.5V$	-20 mA
$V_O = V_{CC} + 0.5V$	+20 mA
DC Output Voltage ( $V_O$ )	-0.5V to $V_{CC} + 0.5V$
DC Output Source or Sink Current ( $I_O$ )	±50 mA
DC $V_{CC}$ or Ground Current per Output Pin ( $I_{CC}$ or $I_{GND}$ )	±50 mA
Storage Temperature ( $T_{STG}$ )	-65°C to +150°C
DC Latch-Up Source or Sink Current	±100 mA
Junction Temperature ( $T_J$ )	
CDIP	175°C
PDIP	140°C

**Note 1:** Absolute maximum ratings are those values beyond which damage to the device may occur. The databook specifications should be met, without exception, to ensure that the system design is reliable over its power supply, temperature, and output/input loading variables. National does not recommend operation of 'LVQ circuits outside databook specifications.

### Recommended Operating Conditions

Supply Voltage ( $V_{CC}$ ) 'LVQ	3.0V to 3.6V
Input Voltage ( $V_I$ )	0V to $V_{CC}$
Output Voltage ( $V_O$ )	0V to $V_{CC}$
Operating Temperature ( $T_A$ )	
74LVQ	-40°C to +85°C
54LVQ	-55°C to +125°C
Minimum Input Edge Rate ( $\Delta V/\Delta t$ )	
$V_{IN}$ from 0.8V to 2.0V	
$V_{CC}$ @ 3.0V	125 mV/ns

### DC Characteristics

Symbol	Parameter	$V_{CC}$ (V)	74LVQ		54LVQ	74LVQ	Units	Conditions
			$T_A = +25^\circ C$		$T_A = -55^\circ C$ to $+125^\circ C$	$T_A = -40^\circ C$ to $+85^\circ C$		
			Typ	Guaranteed Limits				
$V_{IH}$	Minimum High Level Input Voltage	3.0	1.5	2.0	2.0	2.0	V	$V_{OUT} = 0.1V$ or $V_{CC} - 0.1V$
$V_{IL}$	Maximum Low Level Input Voltage	3.0	1.5	0.8	0.8	0.8	V	$V_{OUT} = 0.1V$ or $V_{CC} - 0.1V$
$V_{OH}$	Minimum High Level Output Voltage	3.0	2.99	2.9	2.9	2.9	V	$I_{OUT} = -50 \mu A$
		3.0		2.56	2.4	2.46	V	* $V_{IN} = V_{IL}$ or $V_{IH}$ $I_{OH} = -12 mA$
$V_{OL}$	Maximum Low Level Output Voltage	3.0	0.002	0.1	0.1	0.1	V	$I_{OUT} = 50 \mu A$
		3.0		0.36	0.5	0.44	V	* $V_{IN} = V_{IL}$ or $V_{IH}$ $I_{OL} = 12 mA$
$I_{IN}$	Maximum Input Leakage Current	3.6		±0.1	±1.0	±1.0	μA	$V_I = V_{CC}, GND$

\*All outputs loaded; thresholds on input associated with output under test.

LVQ02

**DC Characteristics** (Continued)

Symbol	Parameter	V <sub>CC</sub> (V)	74LVQ		54LVQ		74LVQ		Units	Conditions
			T <sub>A</sub> = +25°C		T <sub>A</sub> = -55°C to +125°C		T <sub>A</sub> = -40°C to +85°C			
			Typ	Guaranteed Limits						
I <sub>OLD</sub>	†Minimum Dynamic Output Current	3.6					36		mA	V <sub>OLD</sub> = 0.8V Max (Note 1)
I <sub>OHD</sub>		3.6					-25		mA	V <sub>OHD</sub> = 2.0V Min (Note 1)
I <sub>CC</sub>	Maximum Quiescent Supply Current	3.6		2.5		50		25	μA	V <sub>IN</sub> = V <sub>CC</sub> or GND
V <sub>OLP</sub>	Quiet Output Maximum Dynamic V <sub>OL</sub>	3.3	0.6	1.0					V	(Notes 2 & 3)
V <sub>OLV</sub>	Quiet Output Minimum Dynamic V <sub>OL</sub>	3.3	-0.7	-1.0					V	(Notes 2 & 3)
V <sub>IHD</sub>	Maximum High Level Dynamic Input Voltage	3.3	1.7	2.0					V	(Notes 2 & 4)
V <sub>ILD</sub>	Maximum Low Level Dynamic Input Voltage	3.3	1.7	0.8					V	(Notes 2 & 4)

†Maximum test duration 2.0 ms, one output loaded at a time.

**Note 1:** Incident wave switching on transmission lines with impedances as low as 75Ω for commercial temperature range is guaranteed for 74LVQ.

**Note 2:** Worst case package.

**Note 3:** Max number of outputs defined as (n). Data inputs are driven 0V to 3.3V; one output at GND.

**Note 4:** Max number of Data Inputs (n) switching. (n - 1) inputs switching 0V to 3.3V. Input-under-test switching: 3.3V to threshold (V<sub>ILD</sub>), 0V to threshold (V<sub>IHD</sub>), f = 1 MHz.

**AC Electrical Characteristics:** See Section 1.2 for waveforms

Symbol	Parameter	V <sub>CC</sub> * (V)	74LVQ			54LVQ		74LVQ		Units	Fig. No.
			T <sub>A</sub> = +25°C C <sub>L</sub> = 50 pF			T <sub>A</sub> = -55°C to +125°C C <sub>L</sub> = 50 pF		T <sub>A</sub> = -40°C to +85°C C <sub>L</sub> = 50 pF			
			Min	Typ	Max	Min	Max	Min	Max		
t <sub>PLH</sub>	Propagation Delay	3.3	1.5	5.0	7.5	1.0	9.0	1.0	8.0	ns	1.2-3,4
t <sub>PHL</sub>	Propagation Delay	3.3	1.5	5.0	7.5	1.0	9.0	1.0	8.0	ns	1.2-3,4
t <sub>OSSL</sub> , t <sub>OSLH</sub>	Output to Output Skew** Data to Output	3.3		1.0	1.5				1.5	ns	1.2-19

\*Voltage range is 3.3V ± 0.3V

\*\*Skew is defined as the absolute value of the difference between the actual propagation delay for any two separate outputs of the same device. The specification applies to any outputs switching in the same direction, either HIGH to LOW (t<sub>OSSL</sub>) or LOW to HIGH (t<sub>OSLH</sub>). Parameter guaranteed by design.

**Capacitance**

Symbol	Parameter	Typ	Units	Conditions
C <sub>IN</sub>	Input Capacitance	4.5	pF	V <sub>CC</sub> = 3.3V
C <sub>PD</sub> (Note 1)	Power Dissipation Capacitance	20	pF	V <sub>CC</sub> = 3.3V

**Note 1:** C<sub>PD</sub> is measured at 10 MHz.