

Dual Inputs Dual Outputs High Accurate Fast Charger

Features

- Monolithic linear charger requires no inductors, external sense resistors or blocking diodes
- 4.75V to 6.50V operating input voltage range
- It can support up to 30V on Adaptor input and 7V on USB input
- Up to 1.5A total system and charging current
- Provides power to the host system and charges the battery at the same time
- Supports AC wall adapter and USB input
- 4.2V/450mA, available for host system under Adapter input
- It provides 0.5% accuracy of CV mode for 4.2V
- An optional 0.1µF cap on CT pin programs 30 min./ 60 min. timeout for Precharge/Termination.
- Two Thermal limits controls chip temperature and prevents overheating
- Remote sensing pin for Battery voltage
- Pin to pin shortage protection
- Maximum of 1µA battery drain current
- Optional Battery thermistor (NTC) interface
- TQFN-16, RoHS compliant lead-free package

Applications

- Cellular phones and smart phones
- Pocket computers and PDAs
- Digital Still Camera

Product Description

The CM9112 is an integrated linear-mode charger for a single-cell, Lithium-ion battery. It provides both charging current for the battery and power for the host system. It can deliver charging current up to 1A and system current up to 450mA at the same time. It takes power either from AC Adapter or USB Adapter. When both are present it automatically chooses AC Adapter as input.

It requires no external blocking diodes or current sense resistors and uses 2 external resistors to program different charging current under AC Adapter or USB inputs.

The CM9112 provides Precharge Mode, Constant Current Mode (Fast-charge), Constant Voltage Mode and Termination by low current detection. Programmable timeout for Precharge and Termination and Thermistor interface to check Battery Temperature are optional available to the users.

The CM9112 is protected against the use of a wrong high voltage Adapter up to 30V. An antiringing protection on Adaptor input allows the use of a cheaper adaptor without need of a shock inductor.

Pin to pin shortage protection makes it friendly to the users against accidental handling during mounting or checking. The CM9112 is packaged into a miniature 16-pin TQFN package and operates between -40°C and 85°C ambient.

Typical Application

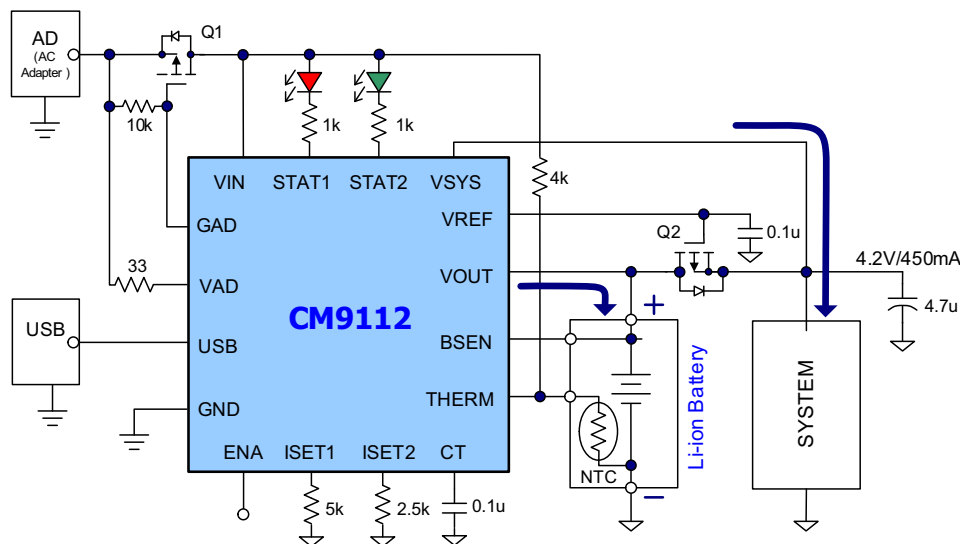

Package Pinout

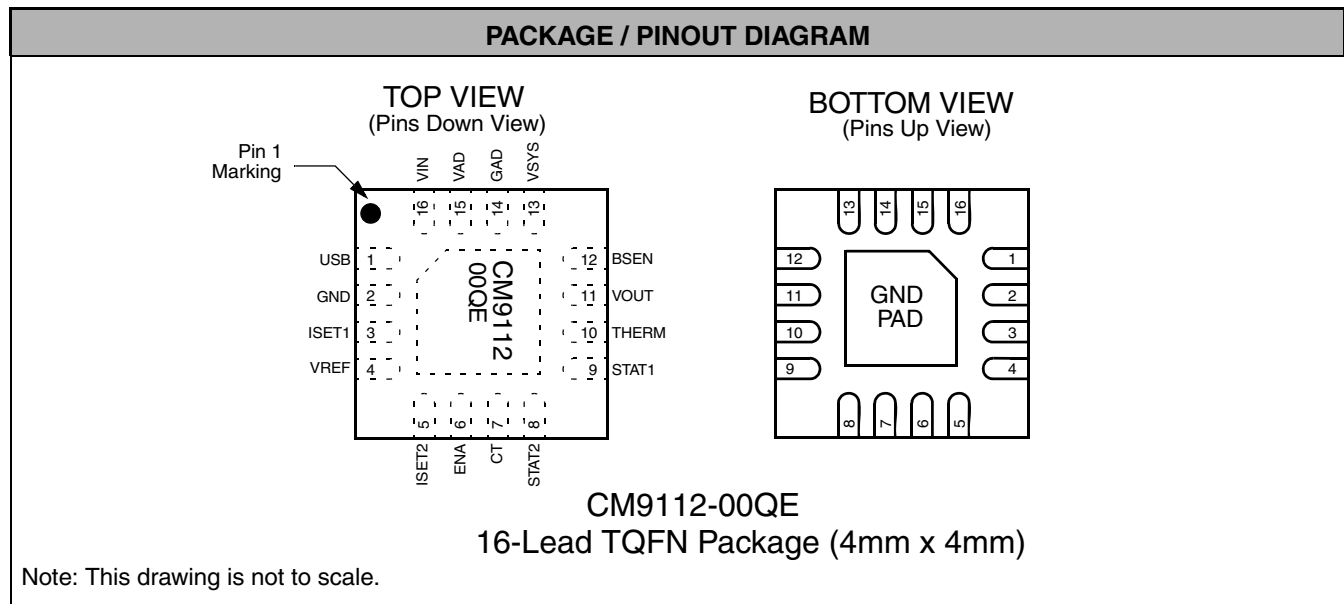
PIN DESCRIPTIONS

LEAD(s)	NAME	DESCRIPTION
1	USB	USB compliant power input pin.
2	GND	Ground pin.
3	ISET1	Pin to set the maximum USB input current; Also, reflects actual charging current. A resistor between this pin and ground sets the charge current, $I_{CH}, \quad R_{ISET1} = \frac{1000 \times 2.5V}{I_{CC}}$
4	VREF	4.2V, 2mA reference output pin.
5	ISET2	Pin to set the maximum charging current in the Fast charge (CC) mode. Also, reflects actual charging current. A resistor between this pin and ground sets the charge current, I_{CH} , $R_{ISET2} = \frac{1000 \times 2.5V}{I_{CC}}$
6	ENA	Enable pin. Logic high (default value) enables charging. Logic low disables charging. ENA does not effect the VSYS output.
7	CT	Pin for capacitor, C_T , for programming the Precharge and Termination timeout period. Timeout1[μ s]=300 x C_T [μ F] Timeout2[μ s]=600 x C_T [μ F]
8	STAT2	Charging status indicator 2 pin (open-drain output).
9	STAT1	Charging status indicator 1 pin (open-drain output).
10	THERM	Thermistor input pin from battery monitoring circuit.

Ordering Information

PIN DESCRIPTIONS		
11	VOUT	Charger output pin (Battery/RF High Power).
12	BSEN	Battery voltage remote sense pin.
13	VSYS	Power output pin to the host system 4.2V/450mA.
14	GAD	Gate drive to external P-MOSFET for adapter input pin.
15	VAD	Adapter input voltage pin.
16	VIN	Positive input supply voltage pin, which powers the charger.

PART NUMBERING INFORMATION			
Pins	Package	Lead Free Finish	
		Ordering Part Number ¹	Part Marking
16	TQFN	CM9112-00QE	CM9112 00QE

Note 1: Parts are shipped in Tape & Reel form unless otherwise specified.

Specifications

ABSOLUTE MAXIMUM RATINGS		
PARAMETER	RATING	UNITS
ESD Protection (HBM)	±1	kV
V _{IN} to GND	[GND - 0.3] to +6.5	V
Pin Voltages		
V _{AD} , GND to GND	[GND - 0.3] to +30	V
V _{OUT} , V _{SYST} , USB to GND	[GND - 0.3] to +7.0	V
EN _A , I _{SET1} , I _{SET2} to GND	[GND - 0.3] to +6.5	V
STAT1, STAT2 to GND	[GND - 0.3] to +6.5	V
BSEN, V _{REF} , CT, THERM to GND	[GND - 0.3] to +6.5	V
Storage Temperature Range	-65 to +150	°C
Operating Temperature Range (Ambient)	-40 to +85	°C
Lead Temperature (Soldering, 10sec)	300	°C

ELECTRICAL OPERATING CHARACTERISTICS (SEE NOTE 1)						
SYMBOL	PARAMETER	CONDITIONS	MIN	TYP	MAX	UNITS
V _{AD}	VAD Operation range		4.75	5.0	6.50	V
V _{USB}	USB Operation range		4.50		5.25	V
I _Q	Quiescent Current	Charging modes, excluding current to and STAT1, STAT2 and THERM pins.		2		mA

Specifications (cont'd)

ELECTRICAL OPERATING CHARACTERISTICS (SEE NOTE 1)						
SYMBOL	PARAMETER	CONDITIONS	MIN	TYP	MAX	UNITS
I_{SHDN}	Shutdown Supply Current	ENA = "LOW", excluding current to STAT1, STAT2 and THERM pins.		50	100	μA
I_{REV}	Battery Reverse Current	Both AC Adapter and USB removed		0.5	1	μA
VAD/USB Supply Voltage						
$UVLO_{VAD}$	UVLO threshold for VAD		4.75	4.8	4.85	V
OVP_{VAD}	OVP threshold for VAD		6.2	6.4	6.5	V
$UVLO_{HYS_VAD}$	UVLO,OVP Hysteresis for VAD			300		mV
I_{IN_AD}	Total input current under Adaptor input	$V_{IN}=5.0\text{V}$; Adaptor in		$I_{IN_AD} = I_{SYS} + I_{VOUT}$	1700	mA
I_{IN_USB}	Total input current with USB plugged-in and Adapter out	$V_{IN}=5.0\text{V}$; USB in, Adaptor out			$I_{IN_USB} = \frac{2500}{R_{SET1(k\Omega)}}$	mA
	USB switch Rds(on)	$I_{IN_USB} = 500\text{mA}$		150	200	$\text{m}\Omega$
Charger Function						
I_{PR}	Precharge Mode Current	$V_{OUT} < 3.2\text{V}$; Adaptor in	$0.85 \times I_{PR}$	$I_{VOUT} = I_{PR} = \frac{250}{R_{SET2(k\Omega)}}$	$1.14 \times I_{PR}$	mA
		$V_{OUT} < 3.2\text{V}$; USB in, Adaptor out	$0.85 \times I_{PR}$	$I_{VOUT} = I_{PR} = \frac{250}{R_{SET1(k\Omega)}}$	$1.14 \times I_{PR}$	mA
V_{CC}	CC Mode Voltage Threshold		3.20	3.30	3.40	V
I_{CC}	CC Mode Charging Current	$V_{OUT} > 3.5\text{V}$; Adaptor in	$0.92 \times I_{CC}$	$I_{VOUT} = I_{CC} = \frac{2500}{R_{SET2(k\Omega)}}$	$1.08 \times I_{CC}$	mA
		$V_{OUT} > 3.5\text{V}$; USB in, Adaptor out	$0.92 \times I_{CC}$	$I_{VOUT} = I_{CC} = \frac{2500}{R_{SET1(k\Omega)}}$	$1.08 \times I_{CC}$	mA
V_{CV}	CV Mode Voltage Threshold		4.190	4.200	4.210	V
I_{TERM}	Charging Termination Current	$V_{OUT} > 4.190\text{V}$; Adapter in	$0.8 \times I_{TERM}$	$I_{VOUT} = I_{TERM} = \frac{25}{R_{SET2(k\Omega)}}$	$1.2 \times I_{TERM}$	mA
		$V_{OUT} > 4.190\text{V}$; USB in, Adapter out	$0.8 \times I_{TERM}$	$I_{VOUT} = I_{TERM} = \frac{25}{R_{SET1(k\Omega)}}$	$1.2 \times I_{TERM}$	mA
V_{RCH}	Recharge Mode Threshold		4.090	4.100	4.110	V

Specifications (cont'd)

ELECTRICAL OPERATING CHARACTERISTICS (SEE NOTE 1)						
SYMBOL	PARAMETER	CONDITIONS	MIN	TYP	MAX	UNITS
CT	Constant-temperature Mode, Limit	(Note 2)	95	105	125	C
OTP	Over-temperature Protection, Limit	(Note 3)	130	140	150	C
OCP	Over-Current Charging (OCP), Limit		1.5	1.7	1.8	A
R _{DSON}	R _{DSON} of Charger MOSFET	I _{CC} = 500mA	100	120	150	mΩ
T _{PR}	Precharge Timeout (Note 4)	Adaptor in; BSEN < 3.2V, CT=0.1μF, 1%	27	30	33	Min.
T _{TER}	Termination Timeout (Note 4)	Adaptor in; BSEN > 4.19V, CT=0.1μF, 1%	54	60	66	Min.
VREF						
V _{REF}	Regulated Voltage V _{REF}	I _{REF} < 1mA	4.190	4.200	4.210	V
VSYS (Available only with Adapter plugged-in) (Note 5)						
R _{DSON}	MOSFET R _{ON}			0.25		Ω
V _{SYST}	Output Voltage Load Regulation	I _{OUT} = 10mA to 300mA	4.1	4.2	4.3	V
		I _{OUT} = 10mA to 450mA	3.9	4.0	4.1	V
I _{SYST}	Output Current available	3.9V < VSYS < 4.3	10		450	mA
I _{LIMIT}	Over-Current Shut-down Threshold	(Note 6)	1200	1500		mA
Control Function						
I _{BSEN}	BSEN Pin Leakage Current	V _{IN} = 0		0.2	1.0	μA
V _{STAT1} V _{STAT2}	STAT1, STAT2 (Open Drain) Output Low Voltage	I _{SINK} = 5mA I _{SINK} = 20mA			0.1 0.5	V V
V _{IHEN}	ENA Input High Level		1.5			V
V _{ILEN}	ENA Input Low Level				0.4	V
Thermistor Function (Note 7, 8)						
V _{BH}	Battery HOT Voltage Threshold (THERM Pin)	V _{IN} = 5.0V (Note 9)	0.9 x V _{BH}	V _{BH} = 0.5 x V _{IN}	1.1 x V _{BH}	V
V _{BC}	Battery COLD Voltage Threshold (THERM Pin)	V _{IN} = 5.0V (Note 9)	0.9 x V _{BC}	V _{BC} = 7/8 x V _{IN}	1.1 x V _{BC}	V
	Hysteresis of V _{BH} , V _{BC}		80	100	120	mV

Note 1: T_A = 25°C unless otherwise specified.

Note 2: When chip temperature reaches 105°C, the IC's internal thermal limit will maintain this temperature by decreasing the programmed charge current.

Note 3: When chip temperature reaches 140°C, the IC goes into a latched shutdown mode. It stops charging, stops supplying VSYS with current from Adapter/USB, and switches VSYS (Baseband) to VOUT (Battery). To resume the charging function, a toggle of VAD/USB is required.

Note 4: The timeout can be disabled by connecting the CT pin to VIN. When enabled, both Timeout1 and 2 are proportional to the value of the capacitor connected on the pin CT. However, the ratio Timeout2/Timeout1 is constant and equal to two. The timing periods are digital, internally generated, based on a clock rate programmable by an external capacitor connected in the CT pin. Timeout feature is available only with AC Adaptor plugged in. Under USB input, both timeout are disabled to allow longer charging time due to low input current available.

Note 5: When both the Adapter and USB are removed, VSYS is switched over to battery, through an external MOSFET, Q2.

Note 6: When the VSYS maximum current limit is reached, LDO1 regulates this current by decreasing VSYS. However, VSYS cannot go below VOUT (battery) by more than one diode's forward voltage (V_{fwd}) due to the body diode of the external MOS-

Specifications (cont'd)

FET, Q2. When this condition occurs, the battery will provide extra current to keep VSYS constant at $V_{batt} - V_{fwd}$. This lasts until the power dissipated in LDO1 triggers the OTP. As a result, there will be no input current to supply either charging or LDO1. Current will still be available from battery to supply VSYS, through the external Q2. To resume charging (after the chip temperature drop below 120°C), the VAD/USB inputs must be toggled.

Note 7: This feature can be disabled by connecting the THERM pin to GND.

Note 8: This function requires that Battery Thermistor should be connected between the THERM pin and GND. Another resistor connected between THERM pin and VIN is required, its value should equal the Thermistor Hot Value (at 50°C). In order to catch both the 0°C and 50°C thresholds (typical range for Li-ion battery) use Thermistors following 7/1 ratio (Thermistor COLD/Thermistor HOT=7).

Note 9: If the battery HOT/COLD detection identifies a condition outside the thresholds, the IC stops charging the battery and waits for the temperature to return to the normal value. During this event, VSYS will continue to be supplied with the required current.

Functional Block Diagram

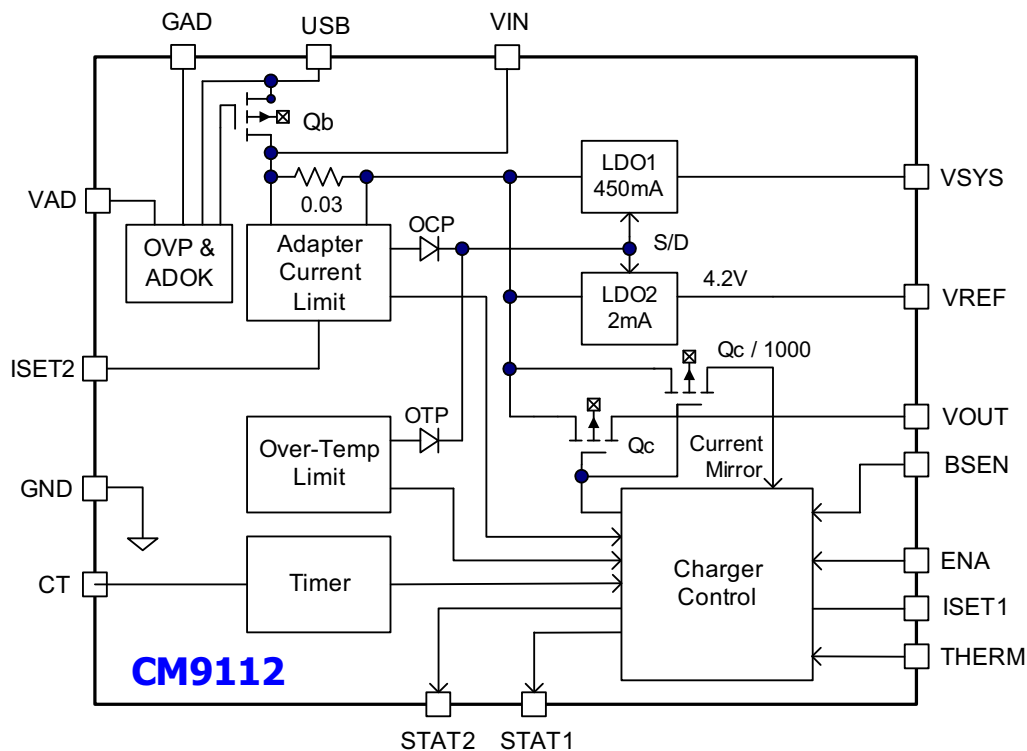

Flow Chart

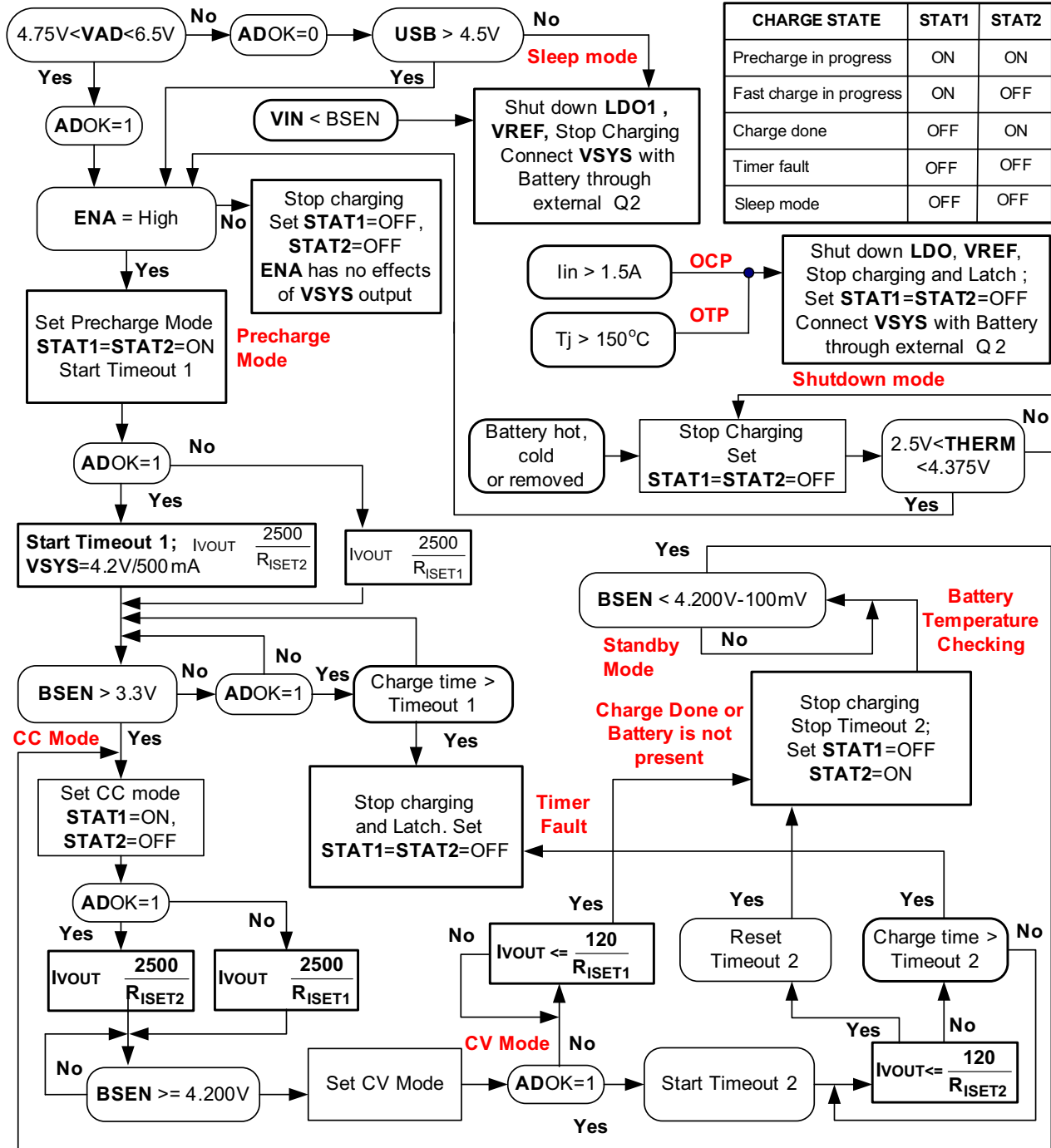

Note: If Therm is used, during any charging mode removing a battery will cause the CV mode then termination, the equivalent to charge done. Until the battery is returned, the charger will cycle between standby mode and recharge cycle.

Application Information

The CM9112 is an integrated charger with a charging profile tailored for single-cell graphite electrode (anode) Li-ion batteries. This linear charger can be powered from either an AC voltage-source adapter or a USB port. When both are applied it will automatically select the AC Adaptor source.

The charger features the three modes required for a safe and reliable Li-ion charging profile; Precharge, Fast-charge, and Termination charge. Extensive safety features include battery temperature monitoring, voltage and current monitoring and charging time limits. Two charging status indicators provide charge state information.

Two different external resistors Riset1, Riset2 allow two different charging current to be programmed for either USB adaptor or AC Adaptor. This method allows an accurate control of USB input current.

Under AC Adaptor input both VSYS (host system) and VOUT (battery) are simultaneously supplied with the current required by each of them, independently. When the absolute over current limit protection is reached (1.5A), CM9112 goes into shutdown, latched mode.

Under USB supply, with AC Adaptor out, CM9112 provide power only to VOUT. The total current available for VOUT is externally programmed by Riset1.

USB/AC adapter dual input

The CM9112 can support inputs from either a USB bus or a 5V AC wall adapter.

The USB standard specifies a 5.0V +/-5% bus voltage, capable of 500mA (High Power peripheral configuration) of current. Since desktop and mobile PCs are equipped with USB or USB2 connectors for interfacing with peripherals and digital consumer electronics, it is advantageous to tap the USB's power to charge portable devices such as cell phones.

When using USB input power, the CM9112 will automatically select external resistor Riset1 to fix the total input current. This goes only into VOUT pin and is intended to charge the battery. However, the system is connected to the battery through a Schottky diode. This makes possible some current flowing into VOUT pin to go not only into Battery but into System too. A longer charging time will be the result of this. That's

why, under USB input, timeout for charger are disabled.

When using AC Adaptor power, CM9112 will automatically select the resistor Riset2 for charging current. In addition of this it will provide a free current to VSYS directly from Adaptor input through a power LDO. This will be limited to 450mA either by power dissipated on the chip, or absolute current limit.

When using a constant-voltage, 5VDC nominal, AC adapter, the semi-regulated voltage to the charger, after accounting for the conduction losses through the power cord and connector contacts, is a voltage in the range of 5.0V to 6.0V. When a valid AC adapter voltage between 4.75V and 6.5V is detected on the VAD pin, an external MOSFET, Q1 is turn ON and VAD and VIN are connected together. An internal power MOSFET used for USB supply, is turned OFF, so there is no residual voltage on USB pin due to VAD supply. The same, when USB is used as input. No residual voltage in VAD pin.

Charging Li-ion Batteries

Once the CM9112 detects the presence of either a valid AC adapter or USB input voltage, and checks that the battery voltage at BSEN is less than V_{IN} and that the battery temperature is within the correct range, it is ready to charge the Li-ion battery. The controller's internal counter is reset.

If the battery voltage is deeply discharged (less than 3.2V), the CM9112 will start in the Precharge mode, charging at 10% of the programmed Fast-charge current level. See [Figure 1](#). While the battery is charging, the status pins will be set to STAT1=0 and STAT2=0. The Precharge current will gradually bring the battery voltage to above 3.2V. If the battery does not reach the 3.2V level, indicative of a defective Li-ion cell, the CM9112 will turn off the charging process after a Pre-charge timeout period (Timeout1, 30 minutes per 0.1 μ F of CT capacitance). In this case, the status pins will be set to STAT1= V_{IN} and STAT2= V_{IN} .

Application Information (cont'd)

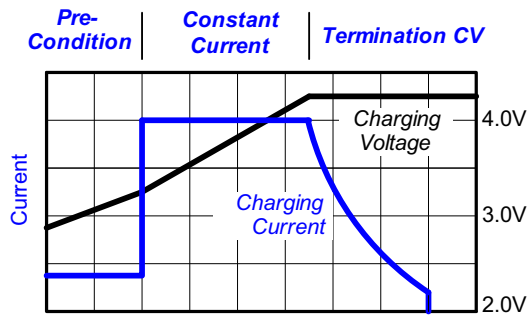

Figure 1. Typical Li-ion Battery Charging Process

Once the battery voltage exceeds the 3.3V threshold, the CM9112 enters the Fast-charge, constant-current (CC) mode. The status pins will be set to STAT1=0 and STAT2=V_{IN}. During the CC mode, the charging current is limited by the maximum charging current, programmed with a single resistor between ISET1 for USB and ISET2 for adaptor:

$$I_{FASTCHG(max)} = \frac{2.5V \times 1000}{R_{ISET1,2}}$$

Most battery manufactures recommend an optimal charging current for their battery. This is typically a time ratio related to the battery capacity, with a value of .7C to 1C, once the battery is above the Precharge voltage level. For example, a 750mAh capacity battery with recommended charge of .7C could have I_{CC} set for about 525mA, with R_{ISET2} equal to 4.75kΩ, 1%.

The actual Fast-charge current might be further limited by the maximum chip temperature limit, determined by the power dissipation on the CM9112 chip, the ambient temperature (T_A), and the junction-to-ambient thermal resistance, R_{th(JA)}. The current requested by System, I_{SYS}, might have a significant contribution to the power dissipated on the chip and reduction of the charging current. So, it is recommended to reduce as much as possible the I_{SYS} current during charging. However, there is not timeout for fast charge period. So, there is no risk to stop the charging, just delay of it.

When the battery voltage reaches 4.200V it goes into CV mode and CM9112 turn from a constant current source to a constant voltage source. As a result, the charging current start dropping. The actual charging current is now determined by the differential voltage

(4.20V – V_{OC}) and the internal impedance, R_{internal}, of the Li-ion battery-pack. When it reaches termination current limit, stop charging is triggered and the Battery is fully charged.

Following the Termination mode, the charger will enter the Standby mode. The status pins will be set to STAT1=V_{IN} and STAT2=0.

If the wall adaptor or USB input is left plugged-in while in the Standby mode, the charger will continue to monitor the battery voltage. It automatically re-charges the battery when the battery voltage drops below the re-charge threshold. When the adaptor is removed, the CM9112 will drain less than 1µA from the battery.

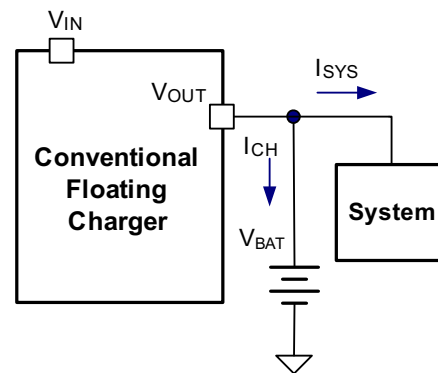

Figure 2. Conventional Charger

Limitations of Conventional Chargers

In a conventional floating charging architecture, the system load is always tied directly to the battery, as shown in Figure 2. If the adapter is charging a deeply discharged battery in the Precharge mode, the system input voltage will be held below 3.2V, the same voltage as the battery voltage. This charger output voltage may be too low to allow a user to use the system, even for non-transmitting (low power) tasks, such as composing emails. Further, in the Precharge mode, the battery charge current is typically limited to 100mA or less. If the system is trying to power up, it may draw more current than the Precharge current limit allows. In this condition, the system will continue to drain power from the battery, potentially causing the battery charger to remain stuck in a Precharge mode indefinitely. After the Precharge timeout expires, the charger, thinking it has a defective battery, will shut down, and the battery is never charged beyond the Precharge mode.

Application Information (cont'd)

When using conventional floating charger with the system load connected directly to the battery, and in the CC mode, where a higher current limit is available, for example, the system can draw a continuous load current of 300mA. However, since the system is always tied to the battery, the charger IC has no way to differentiate the system power demand from the battery charging demand. The charger will limit the total output current to 300mA for the system and 1A for charging the battery. If the battery voltage is low, 3.2V for example, the charger IC power dissipation will be at its worst case, or 3.6W. The charger's junction temperature rises quickly, triggering the over-temperature (OT) current foldback. If the system continues to draw a large current, the battery will then be supplying part of that load current; putting the battery in a discharge mode, rather than in a charge mode. The battery voltage will continue to drop, potentially falling back into a Pre-charge mode condition, and upsetting the charging sequence or forcing the charger to shut down.

Even the charger power dissipation due to the system load alone:

$$PD1 = 1.0A \times (5V - 3.2V) = 1.8W$$

may already exceed the chip's thermal limit and cause OTP to trigger.

The CM9112 Dual Outputs Charge Advantage

To overcome these issues, the CM9112's Fast-charge architecture separates the system power output (LDO1) from the battery charging power output. See Figure 3. With a separate output, the power dissipation contributed by LDO1 in a condition similar to the one above is now only:

$$PD1 = 1.0A \times (5V - 4.2V) = 0.8W$$

In other words, the LDO1 can support the system load, free from the hindrance of the charger, regardless of the battery voltage level. The user can continue use the host system, even when the battery charge voltage is very low, when there is a defective battery, or there is no battery present.

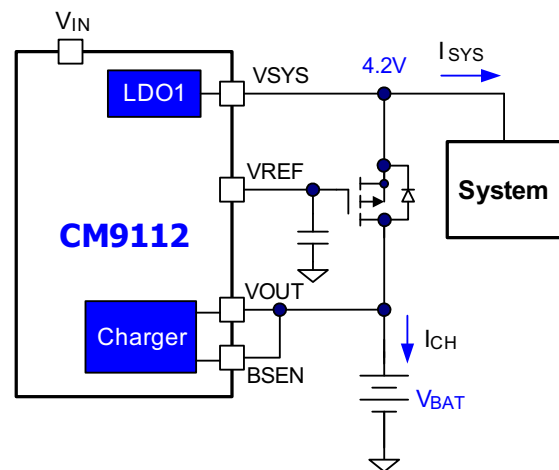

Figure 3. Dual Outputs Charger

Since the CM9112 provides an independent power path to the system, as soon as an adapter is plugged-in, the user can use the system power, even if the battery is dead or in the Precharge mode.

Charging Current Foldback in the Over-temperature Condition

A limitation of linear chargers is that they are vulnerable to over-temperature conditions. The CM9112 will throttle down the charging current when the chip junction temperature reaches 105°C (with 10°C of hysteresis). This protects the charger IC and its nearby external components from excessive temperature.

The Charger IC junction temperature is determined by several factors in the following equation:

$$T_J = T_A + PD + R_{th(JA)} \quad (1)$$

The $R_{th(JA)}$ is usually determined by the IC package and the thermal resistance between the package and the PC board. In particular, a SMD IC package relies on the underlying PC board copper to move the heat away from the junction. The key to reducing the thermal resistance between the IC package and the underlying PC board is using a large copper (Cu) area for solder attach and a large ground plane underneath the charger IC to conduct the heat away.

The power dissipation (PD in equation 1) of a linear charger is the product of input-output voltage differential and output current.

Application Information (cont'd)

$$PD = (V_{IN} - V_{OUT}) \times I_{OUT}$$

In most cases, V_{IN} is fixed at about 5.0V (either the AC adapter or the USB power input). The CM9112 has two outputs; one for the charger and one for the system from LDO1. The total power dissipation is:

$$PD = (5V - 4.2V) \times I_{SYS} + (5V - V_{BAT}) \times I_{FASTCHG}$$

Highest power dissipation occurs when the battery at its lowest level (3.2V), when it just starts in the Fast-charge (CC) mode. Assuming $V_{IN} = 5.0V$, $V_{BAT} = 3.2V$, $I_{CC} = 1A$, the $PD = (5V - 3.2V) \times 1A = 1.8W$. Assuming $R_{th(JA)} = 50^{\circ}C/W$, then $\Delta T = 1.8W \times 50^{\circ}C/W = 90^{\circ}C$. If the ambient temperature (T_A) is $35^{\circ}C$, then the junction temperature (T_J) could reach $125^{\circ}C$ without over-temperature current foldback.

With over-temperature (OT) current foldback, the CM9112 will throttle down the charging current, allowing the junction temperature will reach steady-state equilibrium of $105^{\circ}C$, which translates into 1.4W of power dissipation, or 0.78A of charge current. As the battery voltage rises during charging, the allowable PD dissipation is increased. When the battery voltage reaches 3.6V, a full 1.0A of charging current is allowed.

Dual-Level OTP and OCP

In addition to chip temperature regulation at $105^{\circ}C$, the CM9112 provides absolute over-temperature shutdown protection. In the case of a malfunctioning charger control, high ambient temperature or an unexpectedly high IC thermal resistance, $R_{th(JA)}$ (for example; due to faulty soldering of the charger IC chip), the power dissipation from LDO1 alone could over-heat the device. The CM9112 provides an absolute OTP shutdown at junction temperature of $150^{\circ}C$.

Similarly, each output, LDO1 and VOUT (ISET2), has its own current limit. ISET1 provides the total adapter current limit for adaptive charging current control. However, in case of an inoperative ISET2 setting (for example; R_{ISET2} becomes shorted to ground), ISET1 will function as backup over-current protection. Combining the dual-level OTP and the dual-level OCP, the CM9112 in effect provides four layers of protection against charger or VSYS over-load faults.

The Need for OVP

There are two primary reasons for adding an input OVP feature to the CM9112 charger. One is to protect the charger and the host system when an adapter with the wrong output voltage is plugged-in. The other is to protect the charger IC and the system against input surge voltage resulting from the ringing due to the input capacitor and an inductive adapter power cord.

Almost all computer peripherals and consumer electronics use AC adapters. It is common to use an LCD monitor, a printer, a laptop computer, an ADSL or cable modem, a cell phone, an MP3 player, with all their individual AC adapters clustered around a power strip. The output voltages of these adapters vary, yet most of these use a similar cylindrical style connector at the device interface. Thus, the chance that a user might plug-in a wrong adapter should not be taken lightly.

The CM9112 provides over-voltage protection (OVP) against the plug-in of a wrong adapter, up to an output voltage of 30V. The CM9112 drives a 30V P-type power MOSFET as a disconnect switch. The proprietary OVP design of the CM9112 protects itself and the host system against the intermittent connection of a wrong adapter.

Another source of over-voltage comes from voltage ringing that occurs when an adapter is first plugged-in, as shown in [Figure 4](#). A long power cord from the adapter output can have an inductance of several μH , and the input capacitor of a cell phone is typically a $10\mu F$ to $100\mu F$ ceramic, with very low ESR. Unfortunately, the low resistance in the power cord and the low ESR of the input capacitor provide little dampening to this LC circuit, resulting in strong ringing, with input voltage overshoot, when the adapter is first plugged-in. The ringing could apply a peak voltage twice that of the nominal adapter output voltage at the input capacitor point.

The CM9112 can withstand several forms of OVP conditions; DC, DC with ringing, or intermittent contact of any frequency.

Application Information (cont'd)

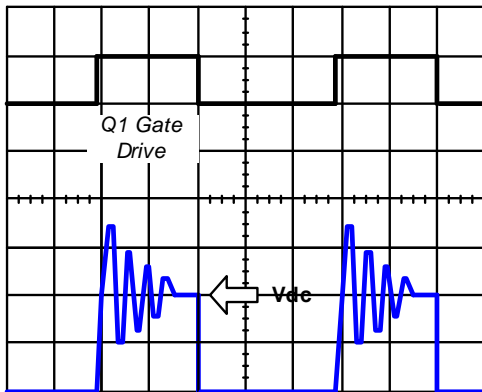

Figure 4. Q1 Response to Undamped Ringing at the Input

Charging status

CM9112 provides two charging status indicator pins: STAT1 and STAT2. These are open-drain outputs, which can drive LEDs directly, with up to 20mA of current sinking capability. Alternatively, the system supervisory microprocessor can monitor the battery charging status by interfacing with these two pins, using a 100kΩ pull-up resistor for each pin. See [Table 1](#).

CHARGE STATUS	STAT1	STAT2
Precharge in progress	Low -	Low -
Fast-charge in progress	Low -	High -
Charge completed	High -	Low -
Charge suspended (including thermistor fault, Precharge or Termination timeout, OTP, OCP and ENA pulled low)	High -	High -

Table 1: Charge Status for STAT1, STAT2

Thermistor Interface

Li-ion batteries are prone to overheating when exposed to excess current or voltage. High heat, combined with the volatile chemical properties of lithium, can cause fire in some cases. The CM9112 provides a thermal interface for over-temperature protection, allowing safe charging of Li-ion cells.

For safety, manufacturers suggest suspending any charging above 45°C and below 10°C until the battery

reaches the normal operating temperature range. Charging below freezing must be avoided because plating of lithium metal could occur. Battery capacity will be reduced if charged between 0°C and +10°C due to the inefficient charging process at low temperatures.

The CM9112 has incorporated a thermistor interface, responsible for the temperature control of the battery-pack through a negative temperature coefficient (NTC) thermistor attached near the battery-pack. The interface surveys the voltage on the THERM pin, which is an input to a window comparator with thresholds associated with two battery-pack fault conditions:

$V_{therm} < 1/2 \times V_{IN}$ for Battery Hot

$V_{therm} > 7/8 \times V_{IN}$ for Battery Cold

To avoid oscillation near the V_{therm} thresholds, both windows have an associated hysteresis of 200mV.

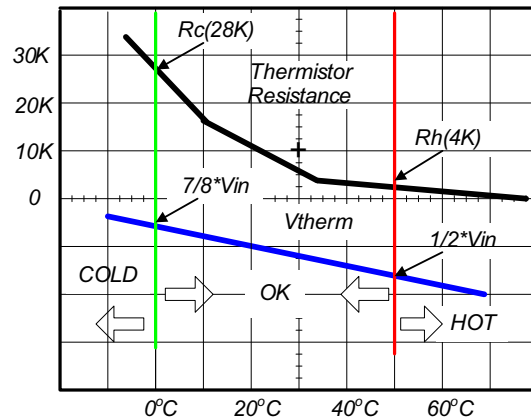

Figure 5. V_{therm} Windows

If the voltage on the THERM pin either exceeds $7/8 \times V_{IN}$, or goes below $1/2 \times V_{IN}$, the CM9112 stops charging and STAT1, STAT2 signal a fault condition (both go high). LDO1 remains fully functional and continues to provide the necessary current to VSYS (the Baseband load). The charging resumes only when the voltage on the THERM pin returns to within the window of $1/2 \times V_{IN}$ to $7/8 \times V_{IN}$. [Figure 5](#) illustrates these windows.

The thermistor interface consists of a thermistor connected between THERM pin and ground, and a resistor, R_{therm} , connected between the THERM pin and

Application Information (cont'd)

VIN, as shown in Figure 6. To determine the proper value for R_{therm}, the thermistor used in the battery-pack should follow the 7:1 ratio on the Resistance vs. Temperature curve (for example, Vishay Dale's R-T Curve 2):

$$\frac{R_{\text{cold}}(\text{at } 0^{\circ}\text{C})}{R_{\text{hot}}(\text{at } 50^{\circ}\text{C})} = 7$$

A thermistor with a room temperature value of about 10k Ω , or higher, will keep the interface current drain from VIN low. Choose the R_{therm} value equal to R_{hot}, with a 0.5% tolerance. A metal film resistor is best for temperature stability.

For example, a typically used thermistor for this application is Vishay Dale's NTHS0603N02N1002J. This thermistor has a R_{hot} (50°C) = 4k Ω and R_{cold} (0°C) = 28k Ω . The thermistor interface will work properly if R_{therm} is 4.02k Ω , 0.5%. At 25°C the thermistor value is 10k Ω . Therefore, a value of voltage at the THERM pin will be:

$$V_{\text{therm}} = \frac{10\text{k}\Omega}{14\text{k}\Omega} \times 5\text{V} = 3.57\text{V } 25^{\circ}\text{C}$$

$$V_{\text{therm}} = \frac{4\text{k}\Omega}{8\text{k}\Omega} \times 5\text{V} = 2.5\text{V } 50^{\circ}\text{C}$$

$$V_{\text{therm}} = \frac{28\text{k}\Omega}{32\text{k}\Omega} \times 5\text{V} = 4.375\text{V } 0^{\circ}\text{C}$$

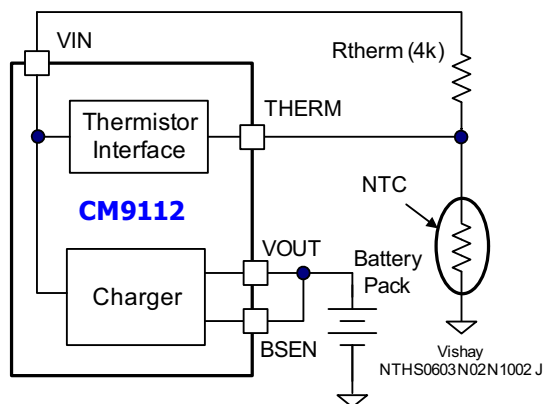

Figure 6. NTC Thermistor Interface

Because the thermistor is typically located on the battery-pack, removal of the battery-pack will remove the thermistor, and cause value of voltage at the THERM pin to go above the window and thus stop charging. This allows the THERM interface to function also as a battery present detector.

When using the CM9112 with a dummy battery, without a thermistor attached, this function can be disabled by connecting the THERM pin to GND. In this case, the THERM interface will never provide a fault condition to stop charge.

If there is no need for the thermistor interface, the THERM pin could be used as a second ENABLE pin for charging control. If the system has an additional control condition for stop charge, then the THERM pin could be used as a second control input. Connecting the THERM pin to VIN will stop charging, while pulling to GND will resume charging.

Timeout Intervals

A programmable timer is used to terminate the Pre-charge and Termination charge modes. There are three modes in a normal charging procedure; Pre-charge, Fast-charge (or CC Mode), and Termination (or CV Mode). Because the first and the third modes take place at low currents, any failure of the battery (for example, excessive leakage current) could cause these modes to continue indefinitely if there was not a Timeout limit.

CM9112 provides two Timeout intervals: Timeout1, which limits Precharge time and Timeout2, which limits the Termination time. These intervals are digitally produced based on an internal clock signal. Timeout1 counts 131072 (2^{17}) clock cycles and Timeout2 counts 262144 (2^{18}) clock cycles. The ratio of Timeout2/Timeout1 = 2 is fixed by the design, but the absolute Timeout values are programmable by an external capacitor, Ct, connected between the CT pin and GND. This capacitor is responsible for the clock cycle rate. Timeout1 time can be calculated as:

$$\text{Timeout1} = 2^{17} \times \frac{13.6\text{ms} \cdot C_t}{0.1\mu\text{F} \cdot 60} \text{ (in minutes)}$$

Application Information (cont'd)

A value of 0.1 μ F provides a 13.6ms clock cycle period, producing 30 minutes for Timeout1 (Precharge) and 60 minutes for Timeout2 (Termination),.

When VIN is applied to a fully discharged battery ($V_{BAT} < 3.0V$), the internal counter starts counting clock cycles for Timeout1. A constant Precharge current (10% of the programmed Fast-charging current) then charges the battery. If Timeout1 elapses before the battery reaches the 3.3V threshold of the Fast-charge (CC) mode, charging stops and a Charge Suspended fault is signaled by the status pins ($STAT1=STAT2=V_{IN}$). This is a latched status and charging can only resume by toggling V_{IN} .

If the battery voltage attains 3.3V before Timeout1 elapses, the internal counter is reset without any action from the charging algorithm and the battery goes into the Fast-charge mode.

During the Fast-charge mode, there is no Timeout counting, and, in theory, this mode can last indefinitely. During Fast-charge, the battery could be providing current to a load. With only part of the available charging current going into the battery, the charging time will increase and becomes unpredictable. Thus, a Timeout interval during this mode is not used, allowing greater application flexibility.

Once the battery reaches the 4.20V threshold, the Termination (CV) mode begins and the charging current starts to decrease. At the same time, the internal clock starts counting again. If Timeout2 elapsed before the Termination current threshold is reached, charging stops in a latched status ($STAT1=STAT2=V_{IN}$). It can resume only by toggling VIN. If the Termination threshold is reached before Timeout2 has elapsed, the counter resets and the charger enters into the Standby mode.

If a stop charge to the battery is triggered by Timeout1/ Timeout2, it should be noted that VSYS would continue to provide power to the Baseband load.

Disabling the Timeouts

To allow design flexibility for many different applications, the CM9112 allows disabling the Timeout intervals as an option. If the application does not require Timeout Intervals to control Precharge and Termination, connecting the CT pin to VIN will disable the func-

tion. The charging algorithm then will be controlled only by voltage on the BSENS pin (Battery Sense Voltage).

Mode Summary

Precharge mode is the typical charge starting mode for pre-conditioning a deeply discharged battery (<3.3V). A constant current of 10% of the programmed Fast-charge current is applied to raise the voltage safely above 3.3V. The maximum charge time is limited to the programmed Timeout1 period.

Fast-charge mode is the constant current charging mode that applies most of the battery charge. A programmed constant current is applied to bring the battery voltage to 4.2V.

Termination mode is the final charging mode, where a constant voltage of 4.2V is applied to the battery until the charge current drops below 5% or the programmed Fast-charge current. The charging time is limited by the programmed Timeout2.

Standby mode is entered after a successful Termination mode and charging is done. Charging stops but VSYS continue to be supplied by AC Adaptor input. In this mode, the battery is monitored, and when its voltage drops below the re-charge threshold (4.100v), a new charge cycle begins.

Shutdown– not latched mode is triggered by a charging fault. These include THERM pin voltage outside the window (battery is too hot, too cold, or removed), or pulling ENA pin low. The charging resumes if the failure condition is removed. VSYS is still alive and supply SYSTEM with current.

Shutdown– latched mode

If input current, sensed internally, exceeds 1.5A (OCP), or the IC junction temperature exceeds 150°C (OTP). The shutdown happens again but this time it is latched. Only by toggling VAD/USB and removing the failure condition the CM9112 could resume the function. VSYS is no more supplied with current and an external Q2 MOSFET connect VSYS with the Battery which become the system power supplier.

Timer-fault mode is entered when a Timeout ends without the battery reaching the proper threshold. Charging stops and remains stopped until VIN is toggled. VSYS will continue to receive power through LDO1.

Application Information (cont'd)

Sleep mode is entered when the Adapter or USB is removed (or is the wrong voltage). Charging stops and VSYS is connected to the battery through Q2. In this mode, the CM9112 draws less than 1µA of current from the battery.

Typical Smartphone Applications

A Smartphone is a cellular or mobile phone with special computer-enabled features not previously associated with telephones, such as advanced data functions. Most mobile phone includes some amount of memory uses such as storing a phone directory, and most can send and receive text messages, but a smartphone can perform many more functions, including PDA, an internet browser, a TV receiver, a multi-pixel camera, or an MP3 player. Compared to standard cell phones, smartphones usually have larger, more colorful displays, contain processors that are more powerful, and typically run operating system software. These features are all packed into a smaller box. This sophistication requires more battery power than a simple cell phone.

Smartphones are available in the two leading cell phone topologies, CDMA and GSM. They each have unique power demands.

The GSM is a TDMA (Time Division Multiple Access) system where up to eight users share a transmitting frequency channel. During transmitting, a GSM phone can draw up to 2.0A of pulse current from the battery (588 µs pulse width, at a duty cycle of 1/8).

When charging the cell phone battery and using the cell phone at the same time, the power amplifier still needs to draw 2A pulse current, which cannot be met with an adapter having less than 2A of rated output current capacity. Most adapters are rated at only 1A. In order to charge the battery and use the phone at the same time, the high-power section (mainly the RF power amplifier), has to be supported by the battery at all times, even when the adapter is plugged-in. See the typical configuration in [Figure 7](#).

With a discharged battery, the charger begins in the Precharge mode, which will only supply 100mA or less of charging current. In the case of very low battery voltage (typically below 3.2V), the cell phone is prohibited from transmitting and drawing large current from the battery.

The CM9112, with its integrated 4.2V, 450mA LDO output, can support the low-power section of a cell phone, such as the system microprocessor, LCD display and LED backlight for the user interface. In addition, the CM9112 can supply power to the system for non-transmitting application such as reading and composing email messages, or synchronizing data transfers between a cell phone and a PC.

The CDMA phone demands lower peak current during transmitting, typically 600mA peak. All the system power can be supplied by LDO1 when configured as shown in [Figure 8](#).

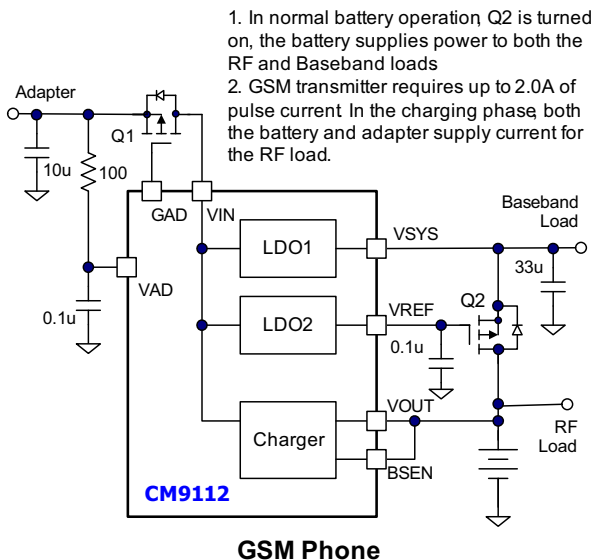

Figure 7. GSM phone application

Application Information (cont'd)

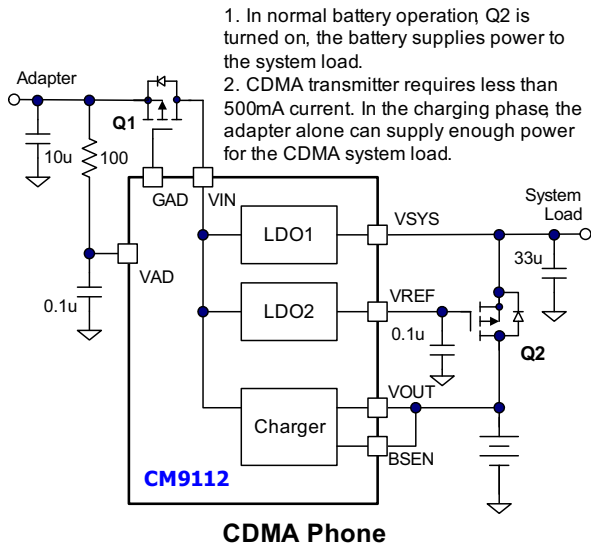

Figure 8. CDMA phone application

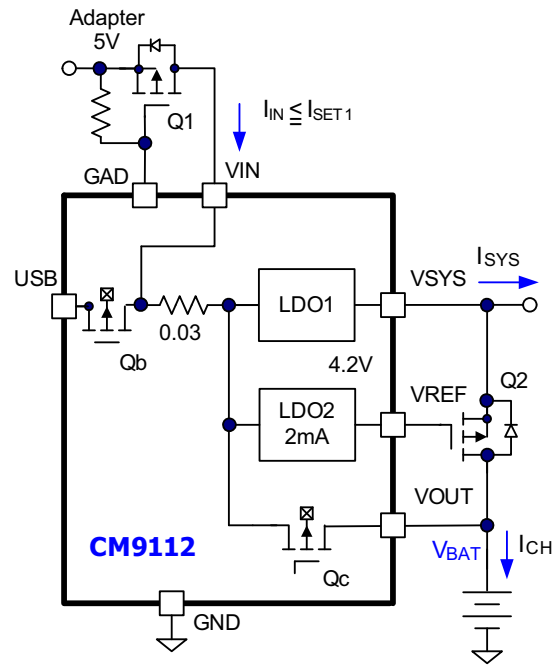

Figure 9. Current paths

Component Selection

The constant voltage AC Adapter must be selected carefully to minimize power losses and heat dissipation in the charger. The input supply should be between 5.0 and 6.0V. The lowest allowable input voltage will minimize heat dissipation and simplify the thermal design. An Adapter rated at 5.0V, 5% at the required input current will provide adequate voltage for the VAD ADOK window.

The output of LDO1, VSYS, requires a 33µF or larger capacitor for good stability and minimum voltage droop during the battery switchover to VSYS at the end of charge. A low-ESR type capacitor will improve system response to load transients. The output of VREF (LDO2), the Q2 gate drive, requires a .1µF ceramic capacitor for stability.

The CM9112 drives two external P-channel MOSFETs (PMOS) to control the charging and system currents. Refer to Figure 9. The most important specifications for the pass PMOS transistors are current rating, R_{DS} and package power dissipation.

In normal operation, Q1 is a fully turned-on switch when an AC adapter is used. The worst-case power dissipation for the input PMOS, Q1, is:

$$P_{Q1} = I_{SET1}^2 \cdot R_{DS}$$

The MOSFET Q1 and PCB heatsink must be rated for this power. Q1 functions as a clamp to limit input voltage transients, and should be selected to handle the worst-case Drain-to-Source voltage, 30V is suggested. The R_{DS} of Q1 should be low enough so that the voltage drop across it will not cause V_{IN} to drop below the minimum of 4.5V when the adapter is at its lowest output. For example, if the adapter is 4.75V minimum at a load of 1.0A and ISET1 is programmed to 1.0A:

$$R_{DS} \leq \frac{(4.75V - 4.5V)}{1.0A} = 250\ m\Omega$$

Q2 is used to supply power to the system from the battery when not charging (adapter removed, end-of-charge, OCP, OTP, etc.). This current passed through Q2. The worst case power dissipation for Q2 would

Application Information (cont'd)

occur when LDO1 is disabled and the battery must supply full system load.

$$P_{Q2} = I_{\text{sys}}^2 \cdot R_{\text{DS}}$$

The Q2 and PCB heatsink must be rated for this power.

Layout Considerations

Because the internal thermal foldback circuit will limit the current when the IC reaches 105°C it is important to keep a good thermal interface between the IC and the PC board. It is critical that the exposed metal on the backside of the CM9112 be soldered to the PCB ground. The Cu pad should be large and thick enough to provide good thermal spreading. Thermal vias to other Cu layers provide improved thermal performance.

VIN, VSYS and VOUT are high current paths and the traces should be sized appropriately for the maximum current to avoid voltage drops. BSEN is the battery feedback voltage and should be connected with its trace as close to the battery as possible.

Mechanical Details

TQFN-16 Mechanical Specifications

The CM9112-00QE is supplied in a 16-lead, 4.0mm x 4.0mm TQFN package. Dimensions are presented below.

For complete information on the TQFN16, see the California Micro Devices TQFN Package Information document.

PACKAGE DIMENSIONS						
Package	TQFN-16 (4x4)					
Leads	16					
Dim.	Millimeters			Inches		
	Min	Nom	Max	Min	Nom	Max
A	0.07	0.75	0.80	0.28	0.030	0.031
A1	0.00		0.05	0.00		0.002
A3	0.20 REF			.008		
b	0.25	0.30	0.35	0.010	0.012	0.014
D	3.90	4.00	4.10	0.154	0.157	0.161
D1	1.95 REF			0.077		
D2	2.00	2.10	2.20	0.079	0.083	0.087
E	3.90	4.00	4.10	0.154	0.157	0.161
E1	1.95 REF			0.077		
E2	2.00	2.10	2.20	0.079	0.083	0.087
e	0.65 TYP.			0.026		
L	0.45	0.55	0.65	0.018	0.022	0.026
# per tape and reel	3000 pieces					
Controlling dimension: millimeters						

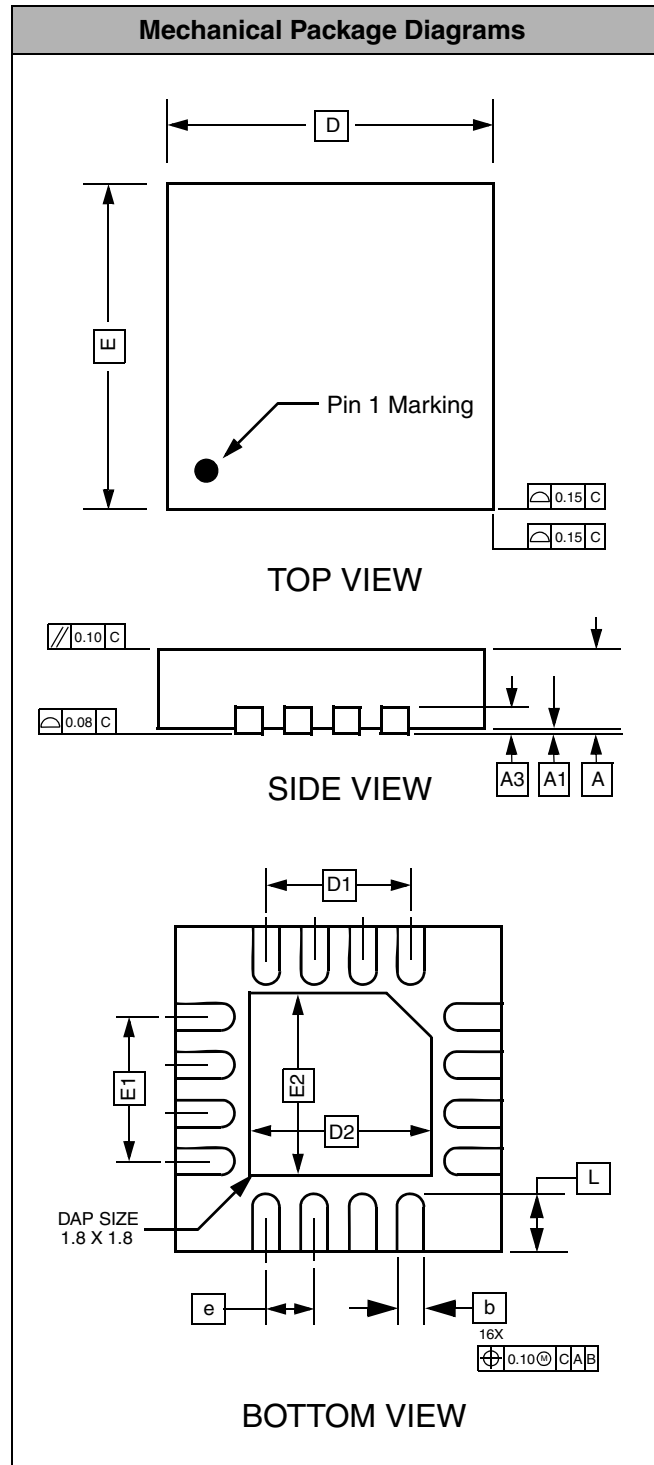

Package Dimensions for 16-Lead TQFN