

REGISTRATION PENDING
Available as FRS244 (D, R, H)

November 1994

Radiation Hardened
N-Channel Power MOSFETs

Features

- 9A, 250V, $R_{DS(on)} = 0.415\Omega$
- Second Generation Rad Hard MOSFET Results From New Design Concepts
- Gamma
 - Meets Pre-Rad Specifications to 100KRAD(Si)
 - Defined End Point Specs at 300KRAD(Si) and 1000KRAD(Si)
 - Performance Permits Limited Use to 3000KRAD(Si)
- Gamma Dot
 - Survives 3E9RAD(Si)/sec at 80% BVDSS Typically
 - Survives 2E12 Typically If Current Limited to IDM
- Photo Current
 - 7.0nA Per-RAD(Si)/sec Typically
- Neutron
 - Pre-RAD Specifications for 1E13 Neutrons/cm²
 - Usable to 1E14 Neutrons/cm²
- Single Event
 - Typically Survives 1E5ions/cm² Having an LET $\leq 35\text{MeV/mg/cm}^2$ and a Range $\geq 30\mu\text{m}$ at 80% BVDSS

Description

The Harris Semiconductor Sector has designed a series of SECOND GENERATION hardened power MOSFETs of both N and P channel enhancement types with ratings from 100V to 500V, 1A to 60A, and on resistance as low as 25m Ω . Total dose hardness is offered at 100K RAD(Si) and 1000KRAD(Si) with neutron hardness ranging from 1E13n/cm² for 500V product to 1E14n/cm² for 100V product. Dose rate hardness (GAMMA DOT) exists for rates to 1E9 without current limiting and 2E12 with current limiting. Heavy ion survival from signal event drain burn-out exists for linear energy transfer (LET) of 35 at 80% of rated voltage.

This MOSFET is an enhancement-mode silicon-gate power field effect transistor of the vertical DMOS (VDMOS) structure. It is specially designed and processed to exhibit minimal characteristic changes to total dose (GAMMA) and neutron (n²) exposures. Design and processing efforts are also directed to enhance survival to heavy ion (SEE) and/or dose rate (GAMMA DOT) exposure.

This part may be supplied as a die or in various packages other than shown above. Reliability screening is available as either non TX (commercial), TX equivalent of MIL-S-19500, TXV equivalent of MIL-S-19500, or space equivalent of MIL-S-19500. Contact the Harris Semiconductor High-Reliability Marketing group for any desired deviations from the data sheet.

Package

TO-257AA

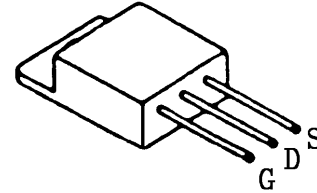

Symbol

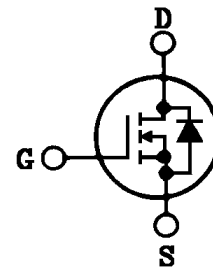

Absolute Maximum Ratings (TC = +25°C) Unless Otherwise Specified

	2N7288D, R, H	UNITS
Drain-Source Voltage	250	V
Drain-Gate Voltage (RGS = 20k Ω)	250	V
Continuous Drain Current		
TC = +25°C	9	A
TC = +100°C	6	A
Pulsed Drain Current	27	A
Gate-Source Voltage	± 20	V
Maximum Power Dissipation		
TC = +25°C	75	W
TC = +100°C	30	W
Derated Above +25°C	0.60	W/°C
Inductive Current, Clamped, L = 100 μ H, (See Test Figure).	27	A
Continuous Source Current (Body Diode)	9	A
Pulsed Source Current (Body Diode)	27	A
Operating And Storage Temperature	-55 to +150	°C
Lead Temperature (During Soldering)		
Distance > 0.063 in. (1.6mm) From Case, 10s Max.	300	°C

Specifications 2N7288D, 2N7288R, 2N7288H - Registration Pending

Pre-Radiation Electrical Specifications TC = +25°C, Unless Otherwise Specified

PARAMETER	SYMBOL	TEST CONDITIONS	LIMITS		UNITS
			MIN	MAX	
Drain-Source Breakdown Volts	BVDSS	VGS = 0, ID = 1mA	250	-	V
Gate-Threshold Volts	VGS(th)	VDS = VGS, ID = 1mA	2.0	4.0	V
Gate-Body Leakage Forward	IGSSF	VGS = +20V	-	100	nA
Gate-Body Leakage Reverse	IGSSR	VGS = -20V	-	100	nA
Zero-Gate Voltage Drain Current	IDSS1	VDS = 250V, VGS = 0	-	1	mA
	IDSS2	VDS = 200V, VGS = 0	-	0.025	
	IDSS3	VDS = 200V, VGS = 0, TC = +125°C	-	0.25	
Rated Avalanche Current	IAR	Time = 20μs	-	27	A
Drain-Source On-State Volts	VDS(on)	VGS = 10V, ID = 9A	-	3.92	V
Drain-Source On Resistance	RDS(on)	VGS = 10V, ID = 6A	-	0.415	Ω
Turn-On Delay Time	td(on)	VDD = 125V, ID = 9A Pulse Width = 3μs Period = 300μs, Rg = 25Ω 0 ≤ VGS ≤ 10 (See Test Circuit)	-	46	ns
Rise Time	tr		-	100	
Turn-Off Delay Time	td(off)		-	368	
Fall Time	tf		-	124	
Gate-Charge Threshold	QG(th)	VDD = 125V, ID = 9A IGS1 = IGS2 0 ≤ VGS ≤ 20	2	8	nc
Gate-Charge On State	QG(on)		29	116	
Gate-Charge Total	QGM		55	220	
Plateau Voltage	VGP		2	10	V
Gate-Charge Source	QGS		4	18	nc
Gate-Charge Drain	QGD		12	48	
Diode Forward Voltage	VSD	ID = 9A, VGD = 0	0.6	1.8	V
Reverse Recovery Time	TT	I = 9A; di/dt = 100A/μs	-	840	ns
Junction-To-Case	Rθjc		-	1.67	°C/W
Junction-To-Ambient	Rθja	Free Air Operation	-	60	

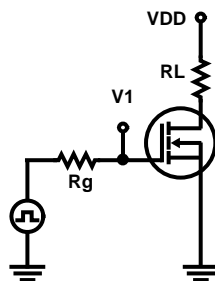

FIGURE 1. SWITCHING TIME TESTING

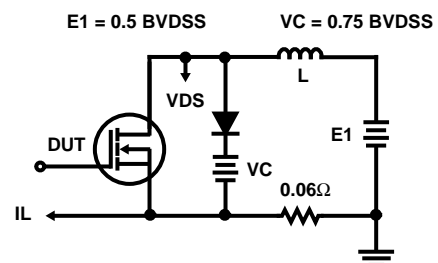

FIGURE 2. CLAMPED INDUCTIVE SWITCHING, ILM

Specifications 2N7288D, 2N7288R, 2N7288H - Registration Pending

Post-Radiation Electrical Specifications TC = +25°C, Unless Otherwise Specified

PARAMETER	SYMBOL	TYPE	TEST CONDITIONS	LIMITS		UNITS	
				MIN	MAX		
Drain-Source Breakdown Volts	(Note 4, 6)	BVDSS	2N7288D, R	VGS = 0, ID = 1mA	250	-	V
	(Note 5, 6)	BVDSS	2N7288H	VGS = 0, ID = 1mA	238	-	V
Gate-Source Threshold Volts	(Note 4, 6)	VGS(th)	2N7288D, R	VGS = VDS, ID = 1mA	2.0	4.0	V
	(Note 3, 5, 6)	VGS(th)	2N7288H	VGS = VDS, ID = 1mA	1.5	4.5	V
Gate-Body Leakage Forward	(Note 4, 6)	IGSSF	2N7288D, R	VGS = 20V, VDS = 0	-	100	nA
	(Note 5, 6)	IGSSF	2N7288H	VGS = 20V, VDS = 0	-	200	nA
Gate-Body Leakage Reverse	(Note 2, 4, 6)	IGSSR	2N7288D, R	VGS = -20V, VDS = 0	-	100	nA
	(Note 2, 5, 6)	IGSSR	2N7288H	VGS = -20V, VDS = 0	-	200	nA
Zero-Gate Voltage Drain Current	(Note 4, 6)	IDSS	2N7288D, R	VGS = 0, VDS = 200V	-	25	μA
	(Note 5, 6)	IDSS	2N7288H	VGS = 0, VDS = 200V	-	100	μA
Drain-Source On-State Volts	(Note 1, 4, 6)	VDS(on)	2N7288D, R	VGS = 10V, ID = 9A	-	3.92	V
	(Note 1, 5, 6)	VDS(on)	2N7288H	VGS = 16V, ID = 9A	-	5.88	V
Drain-Source On Resistance	(Note 1, 4, 6)	RDS(on)	2N7288D, R	VGS = 10V, ID = 6A	-	0.415	Ω
	(Note 1, 5, 6)	RDS(on)	2N7288H	VGS = 14V, ID = 6A	-	0.623	Ω

NOTES:

1. Pulse test, 300μs max
2. Absolute value
3. Gamma = 300KRAD(Si)
4. Gamma = 10KRAD(Si) for "D", 100KRAD(Si) for "R". Neutron = 1E13
5. Gamma = 1000KRAD(Si). Neutron = 1E13
6. Insitu Gamma bias must be sampled for both VGS = +10V, VDS = 0V and VGS = 0V, VDS = 80% BVDSS
7. Gamma data taken 1/30/90 on TA17643 devices by GE ASTRO SPACE; EMC/SURVIVABILITY LABORATORY; KING OF PRUSSIA, PA 19401
8. Single event drain burnout testing by Titus, J.L., et al of NWSC, Crane, IN at Brookhaven Nat. Lab. Dec 11-14, 1989
9. Neutron derivation, HARRIS Application note AN-8831, Oct. 1988

Typical Performance Characteristics

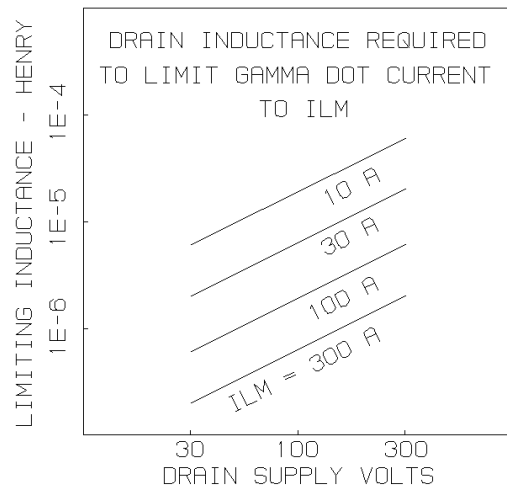
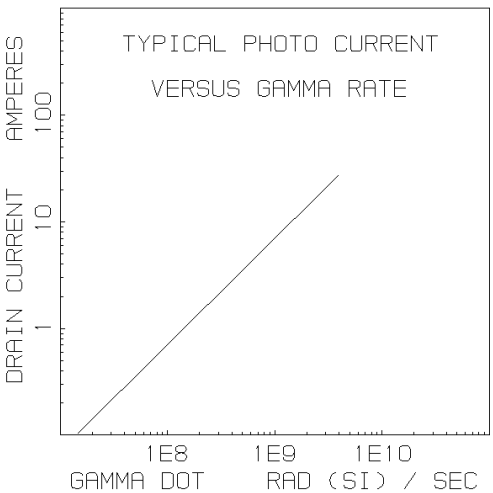
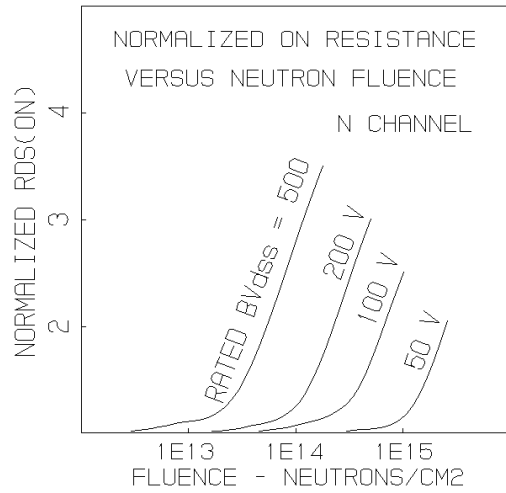
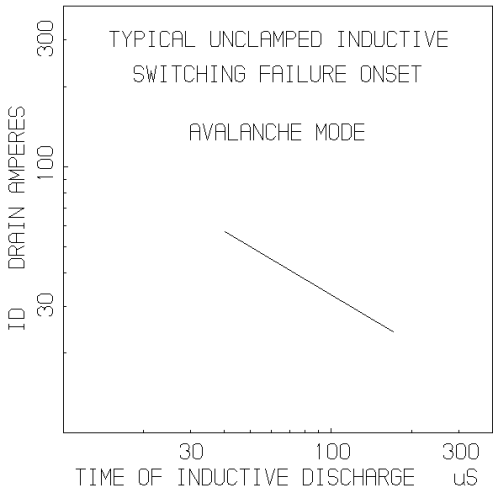
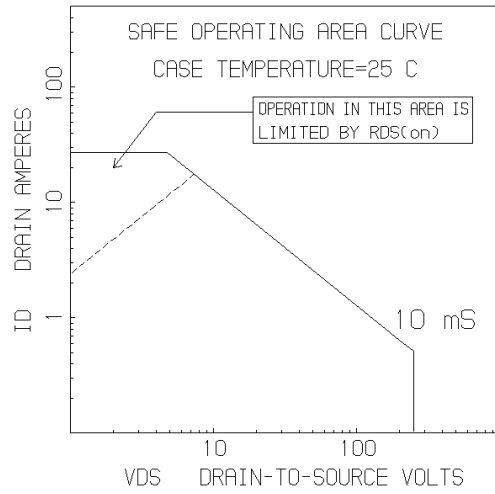
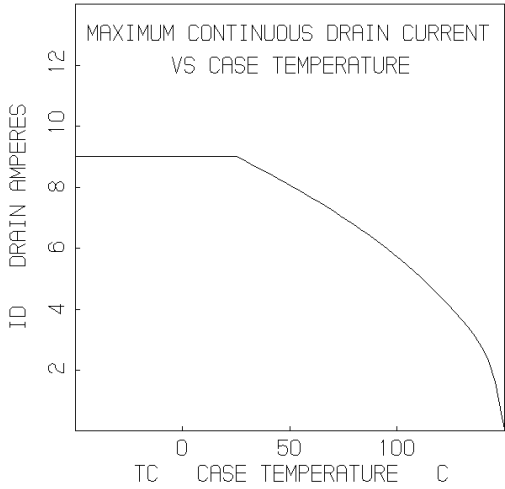

Packaging

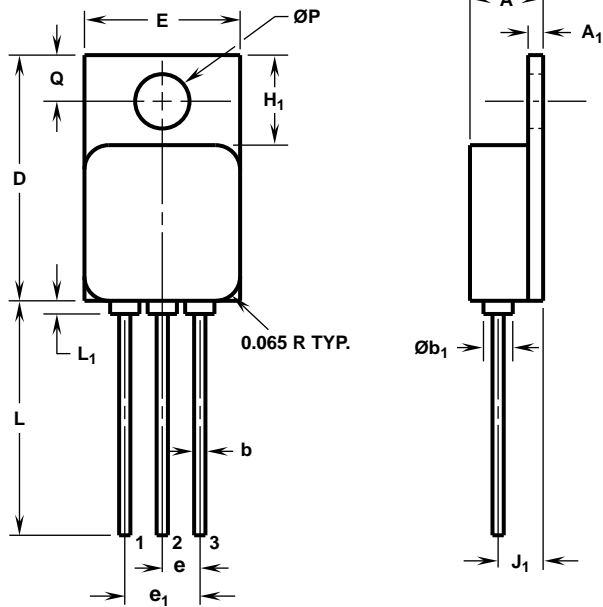

TO-257AA

3 LEAD JEDEC TO-257AA HERMETIC METAL PACKAGE

SYMBOL	INCHES		MILLIMETERS		NOTES
	MIN	MAX	MIN	MAX	
A	0.190	0.200	4.83	5.08	-
A ₁	0.035	0.045	0.89	1.14	-
Øb	0.025	0.035	0.64	0.88	2, 3
Øb ₁	0.060	0.090	1.53	2.28	-
D	0.645	0.665	16.39	16.89	-
E	0.410	0.420	10.42	10.66	-
e	0.100 TYP		2.54 TYP		4
e ₁	0.200 BSC		5.08 BSC		4
H ₁	0.230	0.250	5.85	6.35	-
J ₁	0.110	0.130	2.80	3.30	4
L	0.600	0.650	15.24	16.51	-
L ₁	-	0.035	-	0.88	-
ØP	0.140	0.150	3.56	3.81	-
Q	0.113	0.133	2.88	3.37	-

NOTES:

1. These dimensions are within allowable dimensions of Rev. B of JEDEC TO-257AA dated 9-88.
2. Add typically 0.002 inches (0.05mm) for solder coating.
3. Lead dimension (without solder).
4. Position of lead to be measured 0.150 inches (3.81 mm) from bottom of dimension D.
5. Die to base BeO isolated, terminals to case ceramic isolated.
6. Controlling dimension: Inch.
7. Revision 1 dated 1-93.